

# MOVEX®

# TERFU



***A local extractor with friction joints for worksites where great flexibility is required.***

The TERFU is a local extractor with friction joints designed for use in workplaces where great flexibility is required e.g. laboratories, production environments, and lighter industrial applications.

Simple, easy function.

The friction joints have a large frictional diameter and are supported with ball bearings. The degree of friction is easily adjusted with a one-hand knob. Adapted support springs balance out the weight of the arm. All arms are equipped with a 360 degree rotational swivel mounted in place. An air tight damper is fitted as standard.

Always easy to select the right product.

Terfu is available in two versions:

- Standard version. Suitable for evacuation of most types of airborne contaminants.
- PP version. Most suitable for evacuation of highly corrosive contaminants in high concentrations.

All sizes are suitable for table mounting, ceiling mounting and wall mounting.

The same suction arm is used for suspended mounting from ceilings and walls.

Ceiling and wall brackets both consist of an anodized square aluminum profile for durable surfaces and high stability.

All ceiling brackets are available in eight standard lengths up to 80 inches. Longer lengths can be supplied by special orders.

To further simplify your mounting and provide a cleaner look, an MTI CT escutcheon plate can be used to cover rough cut holes in the false ceiling.

The TERFU system is design protected with several patents- and design protections pending.

***The Movex range also includes fans, accessories, automatic controls and filters suitable for local extraction.***

**LOCAL EXTRACTION**  
**Pure advantages**

# MOVEX® TERFU

## TERFU Model



**Standard version of Terfu** with polypropylene joints and anodized aluminum tubes.

The standard version of Terfu is suitable for evacuation of most types of airborne contaminants from laboratories, schools, hospitals, pharmaceutical industry, nail salons and light industrial applications.



**Polypropylene(PP) version of Terfu** with joints and tubes in recyclable PP. All metal parts that come in contact with the airstream are made from acid resistant stainless steel (SS 2343).

The PP version of Terfu is primarily used for evacuation of extremely corrosive contaminants in high concentrations for certain laboratories, pharmaceutical and chemical industries.

When using a ceiling mounted PP extractor, recommend using an MTI ceiling bracket with internal and external powder coating.

## TERFU Maximum flexibility

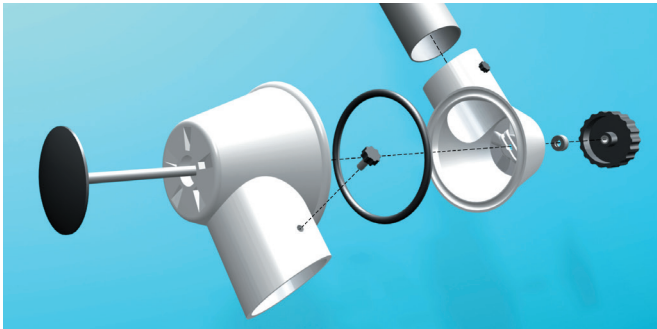

**Terfu joint.** The large frictional diameter together with the single grip adjusting knob provide a rigid, stable joint with a smooth easily adjustable function without requiring the application of excessive force or tools. The joint has reinforced side pieces. Ball bearings that isolate the adjusted friction level allow the arm to move up and down without locking the joint or losing stability and function.

## Appealing stable brackets

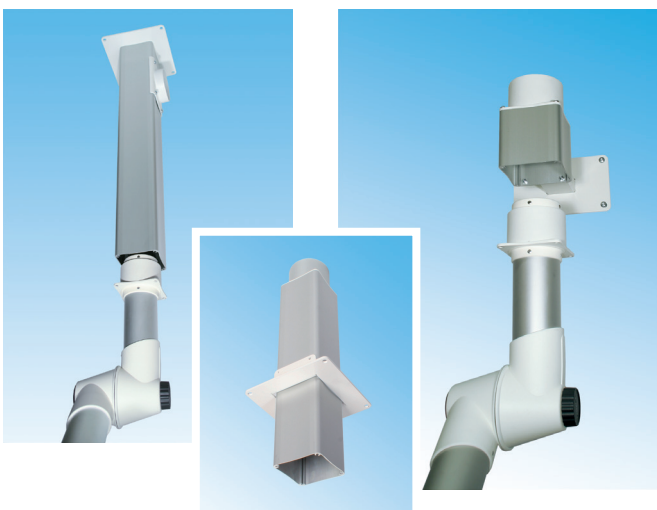

All Terfu extractors have a standard full-swivel that allows 360° of rotation without the need for special sleeves or double wall mountings. Both ceiling and wall brackets consist of a special anodized aluminum profile that provide an appealing, functional installation. The ceiling bracket also acts as the extraction channel, thus avoiding the need for expensive external channeling and additional holes in the finished ceiling.

Installation is simple and stable. The ceiling bracket is available in eight standard lengths from 10 to 80 inches. Lengths greater than 80 inches can be supplied to order. The ceiling mount can be provided with internal epoxy coating for use in aggressive environments.

Ceiling mount		Size (inch)				Weight
Designation		A	B	Total length	C	lb
MT 1000-75	PP	16	12	40	3	5.0
MT 1300-75	PP	22	18	51	3	5.7
MT 1500-75	PP	30	18	60	3	6.0
MT 2000-75	-	40	26	80	3	7.1
MTS 1500-75	PP	30	18	60	3	6.0
MTS 2000-75	PP	40	26	80	3	7.1

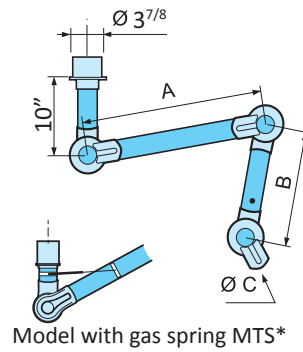

Wall mount		Size (inch)				Weight
Designation		A	B	Total length	C	lb
MV 1000-75	PP	16	12	40	3	9.7
MV 1300-75	PP	22	18	51	3	10.4
MV 1500-75	PP	30	18	60	3	10.7
MV 2000-75	-	40	26	80	3	11.8
MVS 1500-75	PP	30	18	60	3	10.7
MVS 2000-75	PP	40	26	80	3	11.8

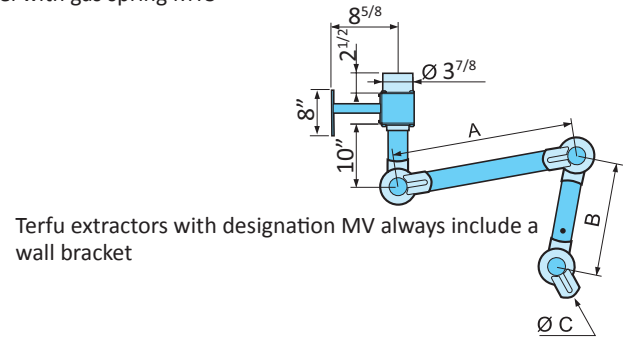
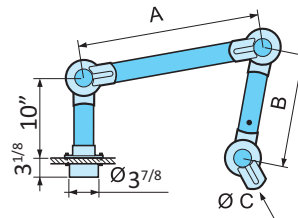
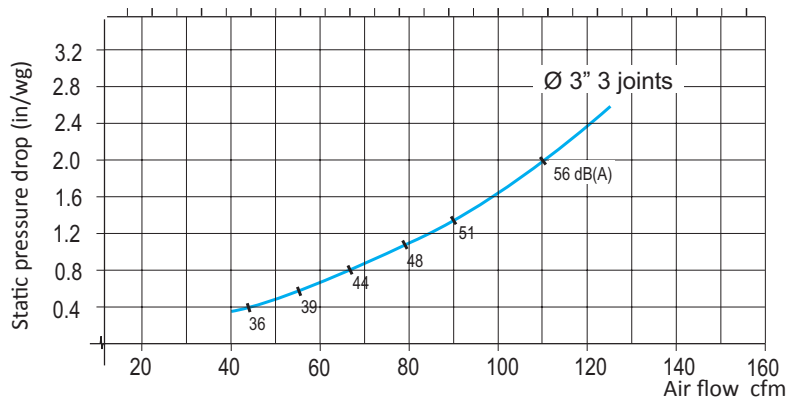

Table mount		Size (inch)				Weight
Designation		A	B	Total length	C	lb
MB 1000-75	PP	16	12	40	3	5.0
MB 1300-75	PP	22	18	51	3	5.7
MB 1500-75	PP	30	18	60	3	6.0



### Pressure drop diagram



The static pressure drop is measured in accordance with ISO-standard 5167-1. The noise level is measured in accordance with ISO-standard 3741.

### Project planning advice

#### Typical values Terfu

Function	Air flow
Laboratory	70-85 cfm
Schools	70-85 cfm

#### Recommended mounting height

Designation	H inch
MT 1000	64-76
MT 1300	72-84
MT 1500	76-88
MT 2000	84-96

#### Recommended side displacement in relation to workplace

Designation	S inch
MT 1000	12-24
MT 1300	16-24
MT 1500	20-32
MT 2000	28-40

#### Range at recommended mounting height

The following mounting heights and side displacements are recommended for optimization of evacuation

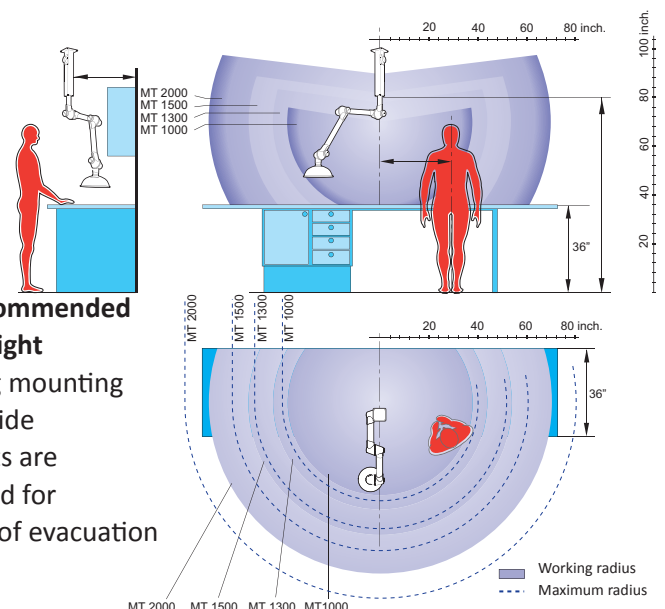

### The MTI and MTF ceiling bracket

The ceiling bracket functions as a simple and stable duct for outgoing air, avoiding the need for expensive ducting and additional holes through false ceilings. **On request, the MTI can be supplied in lengths exceeding 80 inches.**

	Dimensions	Weight
Standard	L (inch)	(lb)
MTI 250	10	6.9
MTI 500	20	8.4
MTI 750	30	9.9
MTI 1000	40	11.4
MTI 1250	50	12.9
MTI 1500	60	14.4
MTI 1750	70	15.9
MTI 2000	80	17.4

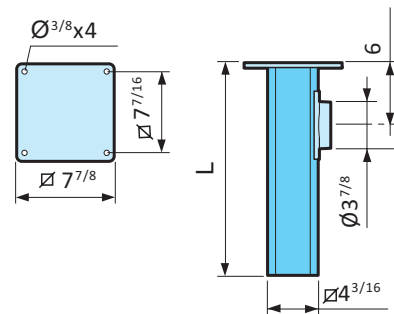
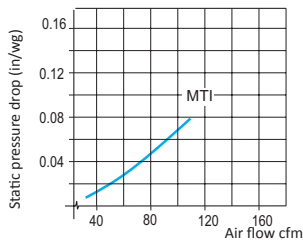

Ceiling bracket, for fitting through beams. The attachment plate is adjustable for the entire length of the aluminum profile. If required, the aluminum profile can be cut during fitting.

	Dimensions	Weight
Standard	L (inch)	(lb)
MTF	40	9.3

The ceiling brackets can be supplied with an epoxy-coated exterior in all lengths. For aggressive environments, we recommend epoxy coating on the interior and exterior.

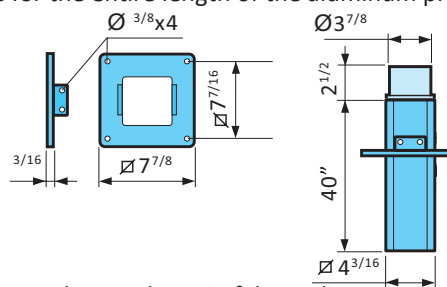

### The MTI CT escutcheon plate

Escutcheon plate, used with the MTI ceiling bracket for stabilization and to cover the rough cut in false ceilings.

	Weight
Standard	(oz)
MTI CT	1.75

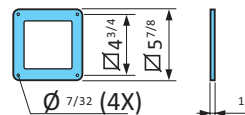

### MVK wall bracket

Wall brackets can be special ordered in custom horizontal and vertical lengths.

	Weight
Standard	(lb)
MVK	4.7

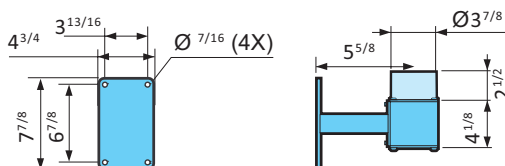

### MBF flexible table bracket

Flexible bracket for attaching to a table-top or shelving. Supplied complete with two clamps.

	Weight
Standard	(lb)
MBF	1.6

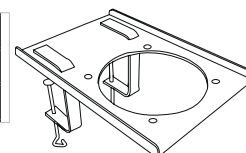

### Hoods

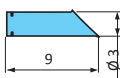

**SUCTION NOZZLE**  
MES 300-75 (PP)  
**Material**  
Standard, Aluminum  
PP, Polypropylene  
**Weight**, 5.6 oz  
**Temp. range**  
-5°F to +176°F

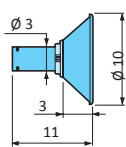

**METAL HOOD**  
MM 250-75  
MMB 250-75 equipped with light.  
**Material**  
Standard, Aluminum  
**Weight**, 11.8 oz  
**Temp. range**  
-5°F to +176°F

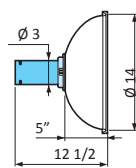

**DOME HOOD**  
MK 350-75 (PP)  
**Material**  
Standard, PETG  
PP, Polypropylene  
**Weight**, 15.9 oz  
**Temp. range**  
-5°F to +176°F

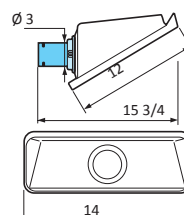

**SQUARE HOOD**  
MSH 350-75  
**Material**  
Standard, PETG  
**Weight**, 17.1 oz  
**Temp. range**  
-5°F to +176°F

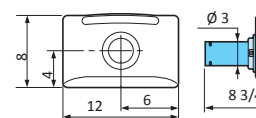

**FLAT SCREEN HOOD**  
MPH 300-75 (PP)  
**Material**  
Standard, PETG  
PP, Polypropylene  
**Weight**, 12.9 oz  
**Temp. range**  
-5°F to +176°F

### Material description

#### Friction joint

Ball-bearing supported adjustable friction joints in polypropylene (PP) with guide ring of low-friction treated rubber. Support springs and other attachment details in zinc plated steel or stainless steel.

#### Tube

Made from thin-wall anodized aluminum, alternatively from polypropylene. Air-tight damper supplied as standard.

#### Fan and filter

Connects to a separate fan, central extractor system or filter. Recommended operating temperature -5°F to +176°F.

### Delivery

**Ceiling/ Wall MET** Supplied assembled, excluding hood. The ceiling or wall brackets should be ordered separately.

**Table-MEB** Supplied assembled, with attachment plate for table fitting, excluding hood. The MBF flexible table bracket should be ordered separately.



104 Commerce Drive, Northampton, PA 18067, USA  
Phone: 610 440-0478, Fax: 610 440-0480  
www.movexinc.com info@movexinc.com